

3-Phase Induction Motor Design

(© Dr. R. C. Goel & Nafees Ahmed)

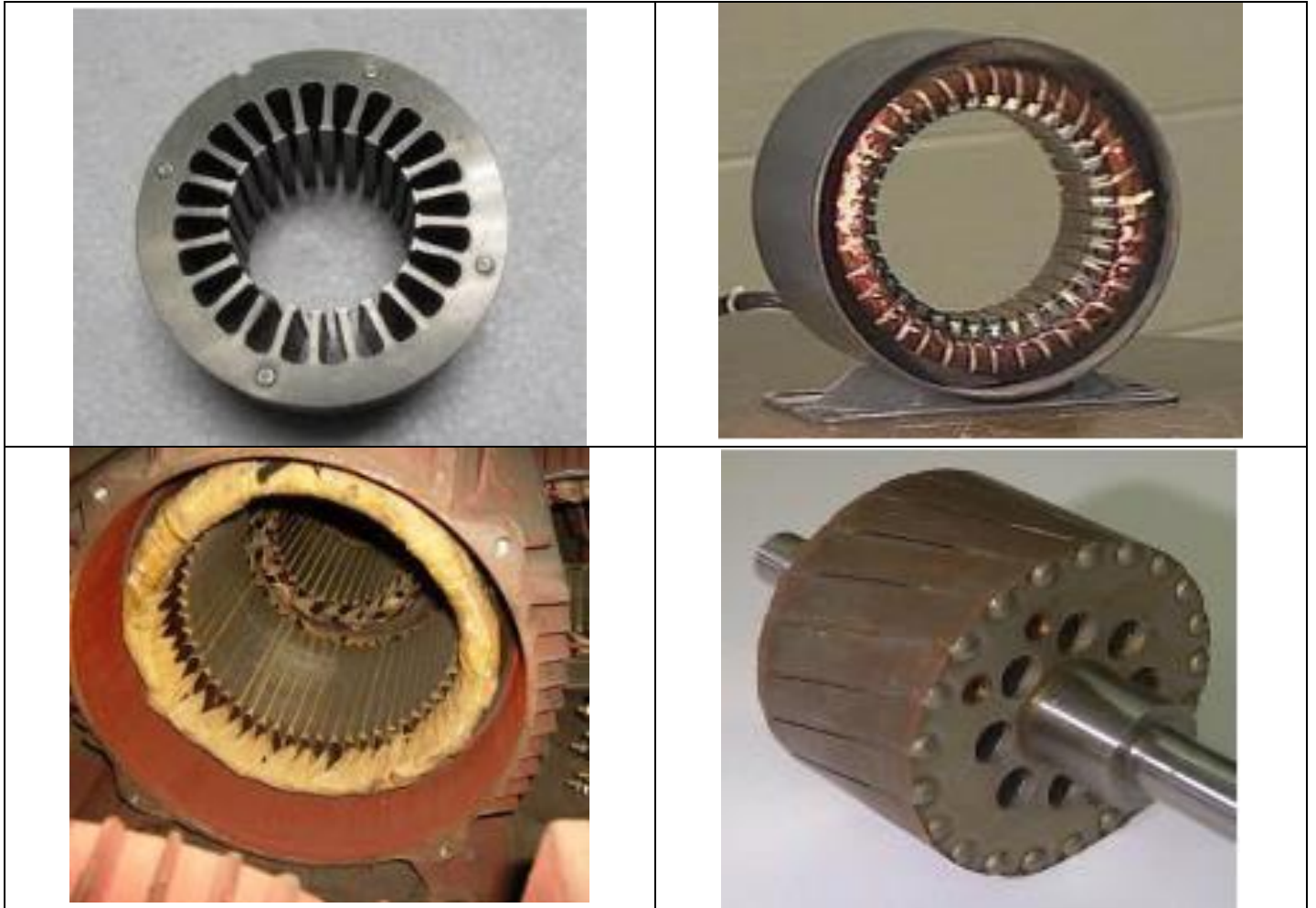

By



Nafees Ahmed

Asstt. Prof. Department of Electrical Engineering
DIT, University, Dehradun, Uttarakhand



References:

1. Notes by Dr. R. C. Goel
2. Electrical Machine Design by A.K. Sawhney
3. Principles of Electrical Machine Design by R.K Agarwal
4. VTU e-Learning
5. www.google.com
6. www.wikipedia.org

OUTPUT EQUATION: - It gives the relationship between electrical rating and physical dimensions (Quantities)

Output of a 3 phase IM is

$$Q = 3V_{ph1} \times I_{ph1} \times \cos\phi \times \eta \times 10^{-3} \quad KW \text{ -----(1)}$$

Where

V_{ph1} = Stator phase voltage

I_{ph1} = Stator Phase current

$\cos\phi$ = Stator power factor

η = Efficiency of motor

Or equation (1) can be written as

$$Q = 3(4.44 \times K_{pd1} \times f \times \phi_1 \times N_{ph1}) \times I_{ph1} \times \cos\phi \times \eta \times 10^{-3} \quad KW \text{ -----(2)}$$

$$(\because V_{ph1} = 4.44 \times K_{pd1} \times f \times \phi_1 \times N_{ph1})$$

Where

f = frequency of supply = $PN/120$

P = No of Poles

N = Speed in RPM

K_{pd1} = Winding factor = 0.955

$\phi_1 = \bar{B} \times \tau_p \times L = \bar{B} \times \frac{\Pi D}{P} \times L$ = Average value of fundamental flux

\bar{B} = Average value of fundamental flux density

τ_p = Pole pitch = $\frac{\Pi D}{P}$

D = Inner diameter of stator

L = Length of the IM

Total No of Conductors on Stator = $3 \times 2N_{ph1} = 6N_{ph1}$

Total Ampere Conductors on Stator = $6N_{ph1} I_{ph1}$

Total Ampere conductors is known as total electric loading

Specific electric loading

It is defined as electric loading per meter of periphery, denoted by \bar{ac} .

$$\bar{ac} = \frac{6N_{ph1} I_{ph1}}{\Pi D}$$

$$\text{Or} \quad N_{ph1} I_{ph1} = \frac{\bar{ac} \Pi D}{6}$$

Putting the values of f , ϕ_1 & $N_{ph1} I_{ph1}$ in equation 2 we get

$$Q = 3 \times 4.44 \times 0.955 \times \left(\frac{NP}{120}\right) \times \left(\bar{B} \times \frac{\Pi D}{P} \times L\right) \times \left(\frac{\bar{ac} \Pi D}{6}\right) \times \cos\phi \times \eta \times 10^{-3} \quad KW$$

$$Q = (17.4 \times 10^{-5} \bar{B} \bar{ac} \cos\phi \eta) D^2 LN$$

$$\text{Or} \quad Q = CD^2 LN \quad KW$$

Where

$$C = \text{Output Co-efficient} = 17.4 \times 10^{-5} \bar{B} \bar{ac} \cos\phi \eta$$

CHOICE OF MAGNETIC LOADING (\bar{B}):

(\bar{B} is average value of fundamental flux density in the air gap)

1. Magnetizing current : *Lower \bar{B}*
2. P.F : *Lower \bar{B}*
3. Iron Loss : *Lower \bar{B}*
4. Heating & Temp rise : *Lower \bar{B}*
5. Overload Capacity : *Higher \bar{B}*

We know

$$V_{ph1} = 4.44 \times K_{pd1} \times f \times \phi_1 \times N_{ph1}$$

If voltage is constant so for *Higher \bar{B}* , N_{ph1} will be less.

And we know

Leakage reactance $\propto N_{ph1}^2 \Rightarrow$ Leakage Reactance \downarrow

$\Rightarrow I_{sc}$ is more \Rightarrow Dia of circle diagram $\uparrow \Rightarrow$ Overload Capacity \uparrow

6. Noise & Vibration : *Lower \bar{B}*
7. Size : *Higher \bar{B}*
8. Cost : *Higher \bar{B}*

Range of $\bar{B} = 0.3$ to 0.6 Tesla

CHOICE OF SPECIFIC ELECTRIC LOADING:

1. Copper Losses : *Lower \bar{ac}*
2. Heating & Temp Rise : *Lower \bar{ac}*
3. Overload Capacity : *Lower \bar{ac}*

If $\bar{ac} \downarrow \Rightarrow N_{ph1} \downarrow$

And we know

Leakage reactance $\propto N_{ph1}^2 \Rightarrow$ Leakage reactance \downarrow

$\Rightarrow I_{sc}$ is more \Rightarrow Dia of circle diagram $\uparrow \Rightarrow$ Overload Capacity \uparrow

4. Size : *Higher \bar{ac}*
5. Cost : *Higher \bar{ac}*

Suitable values of \bar{ac} are

$\bar{ac} = 10,000$ to $17,500$	Amp Cond/meter	up to 10 KW
$= 20,000$ to $30,000$	Amp Cond/meter	up to 100 KW
$= 30,000$ to $45,000$	Amp Cond/meter	> 100 KW

MINI AND MAXI VALUE OF C:

We know

$$C = 17.4 \times 10^{-5} B \text{ ac } \text{Cos}\phi \eta$$

$$C_{\min} = 17.4 \times 10^{-5} \times 0.30 \times 10000 \times 0.80 \times 0.85 \quad (\text{let } \text{Cos}\phi_{\min} = 0.80 \text{ \& } \eta_{\min} = 85\%)$$

$$C_{\min} = 0.35$$

$$C_{\max} = 17.4 \times 10^{-5} \times 0.60 \times 45000 \times 0.85 \times 0.88 \quad (\text{let } \text{Cos}\phi_{\max} = 0.85 \text{ \& } \eta_{\max} = 88\%)$$

$$C_{\max} = 3.5$$

EFFECT OF SPEED ON COST AND SIZE OF IM:

$$D^2 L = \frac{Q}{CN} \Rightarrow \text{Represents the volume of Machine}$$

So for higher speed IM, volume is inversely proportional to speed.
Hence High speed means less volume that is low cost

ESTIMATION OF MAIN DIMENSIONS (D, L):

We know

$$D^2 L = \frac{Q}{CN} \text{ ----- (1)}$$

$$\left\{ \begin{array}{l} \frac{L}{\tau_p} = 1 \quad : \text{ Good Overall Design} \\ = 1 \rightarrow 1.25 \quad : \text{ for Good PF} \\ = 1.5 \quad : \text{ for higher } \eta \\ = 1.5 \rightarrow 2.0 \quad : \text{ Overall Economical Design} \end{array} \right\} \text{----- (2)}$$

Solving equation (1) & (2) we can find out D & L.

Alternate method: Fitting the design into the ‘‘Standard frame size’’.

LENGTH OF AIR GAP:

$$\delta = 0.2 + 2 \times \sqrt{DL} \quad \text{mm}$$

Note: D & L are in Meters

$$\delta_{\min} = 0.25 \text{ mm}$$

For medium rating machines

$$\delta = 2 \rightarrow 3 \text{ mm}$$

Our effort is to keep the length of the air gap as small as possible. If air gap length is higher, then magnetizing current will be more it will result in poor power factor.

EFFECTIVE LENGTH OF MACHINE:

Generally

$$l_1 = l_2 = l_3 = \dots = l_n$$

Let

no_v = No of ventilating ducts

b_v = Width of one ventilating duct

(Generally for every 10 cm of core length there used to be 1 cm ventilating duct)

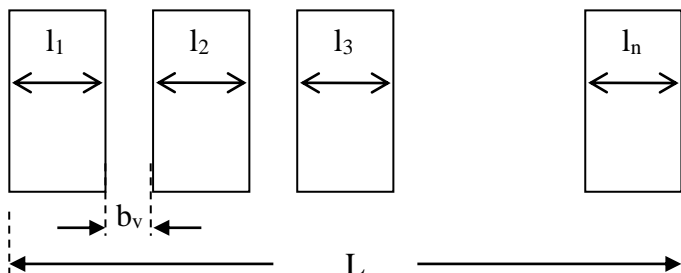

Gross Iron length

$$l = l_1 + l_2 + l_3 + \dots + l_n$$

Actual Iron length

$$l_i = K_i \cdot l$$

Where $K_i =$ Stacking factor
 $= 0.90$ to 0.92

Overall length

$$L = l + n_{ov} \cdot b_v$$

Effective length

$$L_e = L - n_{ov} \cdot b'_v$$

Where $b'_v = b_v \frac{5}{5 + \frac{b_v}{\delta}}$ = Effective width of ventilating duct ($< b_v$ due to fringing)

DESIGN OF STATOR:

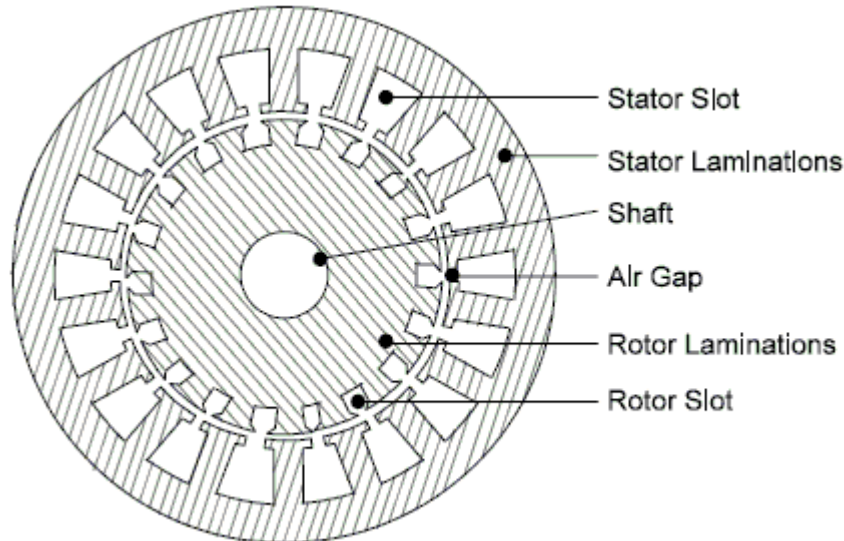

Stator and rotor with semi-closed slots

(1) Shapes of stator slots:

- May be (i) Open Slot: Used for Synchronous M/Cs
 (ii) Partially Closed Slot: Used for Induction M/Cs

(2) No of Stator Slots S_1 : Two approaches

a.
Slot pitch

$$\tau_{sg1} = 15 \rightarrow 20 \text{ mm} = \frac{\pi D}{S_1}$$

$$S_1 = \frac{\pi D}{\tau_{sg1}}$$

So

For 3-Phase IM having P-poles

$$S_1 = 3q_1 P$$

$$q_1 = \frac{S_1}{3P} = \text{No of slots per pole per phase}$$

Where

Winding may be integral (q_1 is integer) or fractional (q_1 is fractional) slot winding.

If q_1 is fractional, say

$$q_1 = \frac{x}{y} = m \frac{n}{y}$$

Let $q_1 = \frac{16}{3} \Rightarrow 5 \frac{1}{3} \Rightarrow y=3$
 If poles are 4 then pole pairs=2
 Select $q_1 = 5 \frac{1}{2} \Rightarrow y=2$

Then for windings to be symmetrical it is essential that the denominator 'y' should be such that the no of pole pair is divisible by 'y'.

If double layer winding is to be use then 'y' should be divisible by 2.

Hence S_1 is estimated.

b. Select $q_1=3$ to 10 and then find S_1 .

(3) Estimation of No of turns per Phase (N_{ph1}), Total no of conductors (Z_1) & No of conductors per slots (N_{c1}):

We know

$$V_{Ph1} = 4.44 \times K_{pd1} \times f \times \phi_1 \times N_{Ph1} \quad \text{----- (1)}$$

So
$$N_{Ph1} = \frac{V_{Ph1}}{4.44 \times K_{pd1} \times f \times \phi_1} \quad \text{----- (2)}$$

Where

$$\phi_1 = \bar{B} \times \tau_p \times l_e = \bar{B} \times \frac{\Pi D}{P} \times L_e \quad \text{----- (3)}$$

$$Z_1 = 3 \times 2N_{Ph1} = 6N_{Ph1} \quad \text{----- (4)}$$

$$N_{c1} = \frac{Z_1}{S_1} \quad \text{----- (5)}$$

N_{c1} Must be an integer and divisible by 2 for double layer windings. If not an integer make it integer and hence find the corrected value of N_{c1} that is $N_{c1,corrected}$. Also find out the corrected values of

Followings

$Z_{1,corrected}$ Using equation (5)

$N_{Ph1,corrected}$ Using equation (4)

$\phi_{1,corrected}$ Using equation (1)

$\bar{B}_{corrected}$ Using equation (3)

(4) Sectional area of stator conductor (F_{c1}):

Per phase stator current

$$I_{Ph1} = \frac{Q \times 10^3}{3V_{Ph1} \cos\phi \eta}$$

$$F_{c1} = \frac{I_{Ph1}}{\delta_1} \quad mm^2$$

So

Where $\delta_1 = \text{Current density} = 3 \rightarrow 4 \text{ A/mm}^2$

From ICC (Indian Cable Company) table, find d_c corresponding to F_{c1}

SWG	F_{c1} (mm ²)	d_c (mm)	$d_{overall}$ (mm)
50		0.025	
25		0.5	
1		7.62	

(5) Stator slot design:

Let

n_v = No of conductors vertically

n_h = No of conductors horizontally

So $N_{c1} = n_v * n_h \quad \text{----- (1)}$

$$\frac{n_v}{n_h} = 3 \rightarrow 5 \text{ ----- (2)}$$

Solving equation (1) & (2) find out n_v & n_h .

Height of slot

$$h_{s1} = n_v \cdot d_c + 3 \cdot 0.5 + 3.5 + 1.5 + 2 \text{ mm} \quad (0.5 \text{ mm is insulation thickness and } 2 \text{ mm for slack \& tolerance})$$

Width of the slot

$$b_{s1} = n_h \cdot d_c + 2 \cdot 0.5 + 2 \text{ mm} \quad (0.5 \text{ mm is insulation thickness and } 2 \text{ mm for slack \& tolerance})$$

Slot opening

$$b_{o1} = \frac{2}{5} b_{s1}$$

Ratio

$$\frac{h_{s1}}{b_{s1}} = 3 \rightarrow 5$$

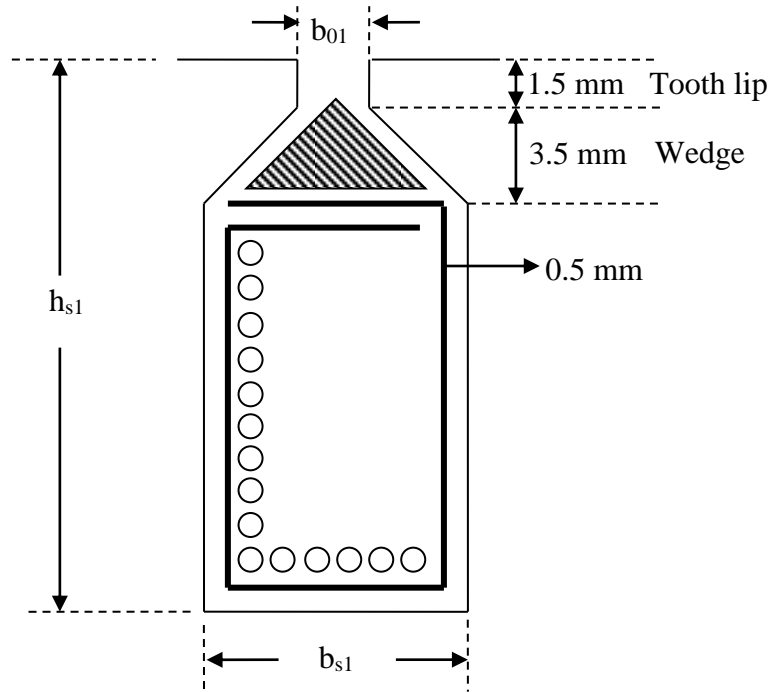

Partially closed slot for 400Volts IM

Thickness of insulation

With mica or leatheroid insulation for small rating machines

KV	0.4	1.1	3.3	6.6	11	15
mm	0.5	0.75	1.5	2.5	4	5.5

With improved insulation (Semica Therm)

KV	2	3	6	10	16	25
mm	1.1	1.4	1.8	2.8	4.0	6.0

$$\text{Thickness} = 0.215 \text{ KV} + 0.7 \text{ mm}$$

Advantages of Semica Therm:

- Much better heat is dissipated for higher rating machines due to less thickness of wall insulations.
- Insulation occupies little less space in the slot.

(6) Length of mean turns (L_{mt1})

$$L_{mt1} = 2L + 2.3\tau_p + 0.24$$

Where $\tau_p = \text{Pole pitch} = \frac{\pi D}{P}$

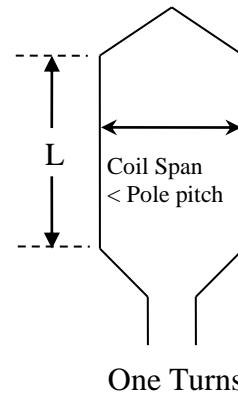

(7) Resistance of stator winding per phase (R_{ph1})

$$R_{ph1} = 0.021 \times 10^{-6} \times \frac{L_{mt1}}{F_{cl}} N_{ph1}$$

(8) Total copper loss in the stator winding

$$= 3 I_{ph1}^2 R_{ph1}$$

(9) Flux density in stator tooth

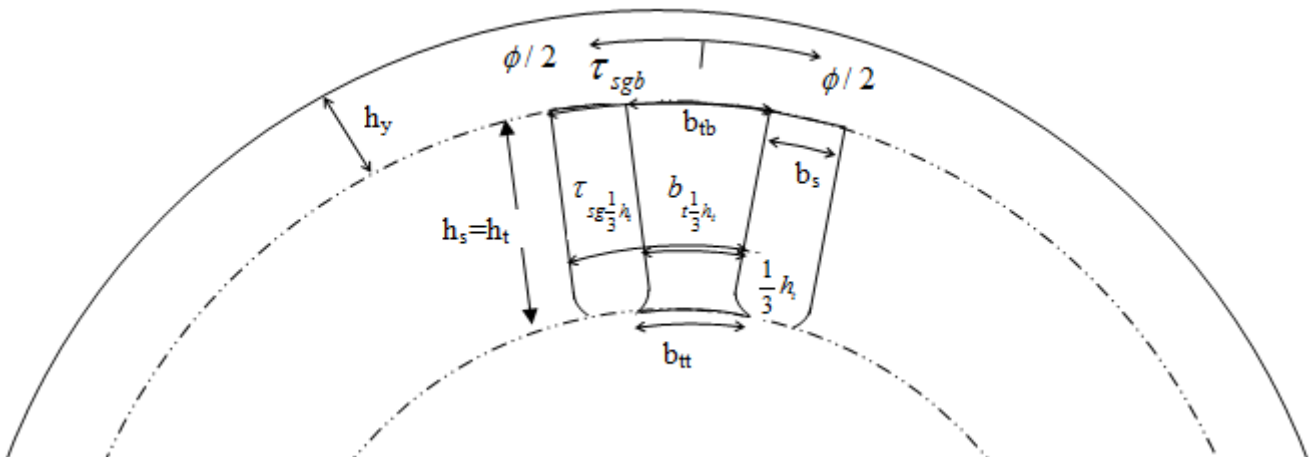
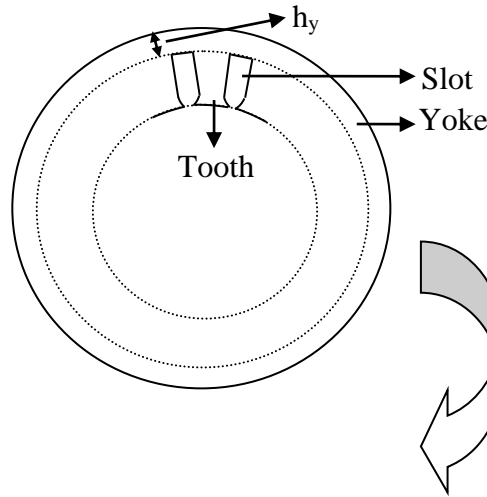

Maximum flux density in stator tooth should not exceed 1.8T; otherwise iron losses and magnetizing current will be abnormally high. (So if flux density >1.8T, change slot dimensions)

Mean flux density in the stator tooth is calculated at $\frac{1}{3}^{rd}$ of tooth height from the narrow end of the stator tooth.

Dia of stator at $\frac{1}{3}$ of tooth height from narrow end

$$D_{\frac{1}{3}h_t} = D + \frac{1}{3}h_s \times 2$$

Slot pitch at $\frac{1}{3}$ of tooth height from narrow end

$$\tau_{sg \frac{1}{3}h_t} = \frac{\Pi D_{\frac{1}{3}h_t}}{S_1}$$

Width of the tooth at $\frac{1}{3}$ of tooth height from narrow end

$$b_{\frac{1}{3}h_t} = \tau_{sg \frac{1}{3}h_t} - b_s$$

Area of one stator tooth at $\frac{1}{3}$ of tooth height from narrow end

$$= b_{\frac{1}{3}h_t} \times K_i l \quad (\text{Where } l_i = k_i l = \text{Actual iron length})$$

Area of all the stator teeth under one pole

$$\begin{aligned} A_{\frac{1}{3}h_t} &= \text{Area of one tooth} \times \text{No of teeth per pole} \left(\frac{S_1}{P} \right) \\ &= b_{\frac{1}{3}h_t} \times K_i l \times \left(\frac{S_1}{P} \right) \\ &= \left[\frac{\Pi \left(D + \frac{1}{3}h_s \times 2 \right)}{S_1} - b_s \right] \times K_i l \times \left(\frac{S_1}{P} \right) \end{aligned}$$

So mean flux density in teeth

$$B_{\frac{1}{3}h_t} = \frac{\phi_1}{A_{\frac{1}{3}h_t}}$$

(10) Depth (Height) of stator yoke (h_y):

Flux through stator yoke is half of the flux per pole

$$\frac{\phi_1}{2} = B_y \times h_y K_i l$$

Where B_y = flux density in yoke

$$= 1.3 \text{ to } 1.5 \text{ T}$$

So
$$h_y = \frac{\phi_1 / 2}{B_y K_i l}$$

(11) Outer dia of IM (D_o):

$$D_o = D + 2h_s + 2h_y$$

(12) Estimation of iron losses:

Corresponding to flux density in tooth $B_{\frac{1}{3}h_t}$ find out iron loss per Kg from the graph given on page 19, fig 18. So $B_{\frac{1}{3}h_t} \Rightarrow p_{it} \text{ W/Kg}$

Iron loss in teeth

$$= p_{it} * \text{density} * \text{volume of iron in teeth}$$

$$= p_{it} * 7600 * \text{volume of iron in teeth}$$

Corresponding to flux density in yoke B_y find out iron loss per Kg from the graph given on page 19, fig 18. So $B_y \Rightarrow p_{iy} \text{ W/Kg}$

Iron loss in yoke

$$= p_{iy} * \text{density} * \text{volume of iron in yoke}$$

$$= p_{iy} * 7600 * \text{volume of iron in yoke}$$

Total iron losses $P_i = \text{Iron loss in teeth} + \text{Iron loss in yoke}$

So
$$I_C = \frac{P_i}{3V_{Ph1}}$$

ROTOR DESIGN:

(1) Estimation of rotor no of slots (S_2)

If $S_1 = S_2$, cogging will take place and slot selection also affects noise & vibrations. So as a general rule to avoid crawling, cogging and keeping noise & vibrations low, following slot combinations are selected

$$q_1 - q_2 = \pm 1, \pm \frac{1}{3}, \pm \frac{2}{3} \dots\dots\dots$$

$$q_2 = q_1 \pm 1, \pm \frac{1}{3}, \pm \frac{2}{3} \dots\dots\dots$$

Where, q_1 & q_2 are no of slots per pole per phase for stator and rotor respectively.

So No of rotor slots

$$S_2 = 3q_2P$$

(2) Estimation of rotor no of turns, conductors etc

(a) Wound rotor IM:

We may keep

$$\frac{V_{Ph2}}{V_{Ph1}} = \frac{N_{Ph2}}{N_{Ph1}} = 0.5 \rightarrow 0.6$$

So No of turns per phase on rotor

$$N_{Ph2} = (0.5 \rightarrow 0.6)N_{Ph1}$$

Total no of conductors on rotor

$$Z_2 = 6N_{Ph2}$$

Conductors per slot for rotor

$$N_{C2} = \frac{Z_2}{S_2} \quad \text{Make it } (N_{C2}) \text{ integer if not and divisible by 2 for 2 layer winding. Hence find}$$

out correct value of N_{C2} , N_{Ph2} & Z_2 i.e. $N_{C2,Corrected}$, $N_{Ph2,Corrected}$, $Z_{2,Corrected}$

(b) Cage rotor IM:

No of rotor bars

$$Z_{2bar} = S_2$$

(3) Rotor current (I_{Ph2})

It is assumed that 85% of ampere turns get transferred to the rotor.

$$\text{Ampere turns on stator} = 3 I_{Ph1} N_{Ph1}$$

(a) Wound rotor IM:

$$\text{Ampere turns on rotor} = 3 I_{Ph2} N_{Ph2}$$

$$\text{So } 3 I_{Ph2} N_{Ph2} = 0.85 \times 3 I_{Ph1} N_{Ph1}$$

$$\text{Or } I_{Ph2} = \frac{0.85 \times I_{Ph1} N_{Ph1}}{N_{Ph2}}$$

(b) Cage rotor IM:

$$\text{Ampere turns on rotor} = I_{2bar} \frac{S_2}{2}$$

$$\text{So } I_{2bar} \frac{S_2}{2} = 0.85 \times 3 I_{Ph1} N_{Ph1}$$

$$\text{Or } I_{2bar} = \frac{0.85 \times 6 I_{Ph1} N_{Ph1}}{S_2}$$

End ring current

$$I_{2endring} = \frac{S_2 \times I_{2bar}}{\Pi P}$$

(4) Size of rotor conductors:

(a) Wound rotor IM:

X-sectional area of rotor conductor

$$F_{C2} = \frac{I_{Ph2}}{\delta_2}$$

Where δ_2 = Current density in rotor winding
= 4 to 5 A/mm²

(Higher than stator current density because rotor is rotating so cooling is increased hence, δ_2 is more)

SWG or strip conductors may be used.

(b) Cage rotor IM:

X-sectional area of rotor bar

$$F_{C2bar} = \frac{I_{2bar}}{\delta_{bar}}$$

Where δ_{bar} = Current density in rotor bar
= 5 to 7 A/mm²

(Higher than stator & wound rotor because rotor conductors are bare that is no insulation so better heat conduction resulting in better cooling so δ is more)

If round bars are used then dia of bar

$$F_{C2bar} = \frac{\Pi}{4} d_{2bar}^2$$

$$\text{Or } d_{2bar} = \sqrt{\frac{4 F_{C2bar}}{\Pi}}$$

X-sectional area of rotor endring

$$F_{C2ending} = \frac{I_{2ending}}{\delta_{bar}}$$

Current density in end ring is same as current density in bar.

(5) Flux density in rotor tooth

(Note: This is same as flux density in stator tooth)

Dia of rotor at $\frac{1}{3}$ of tooth height from narrow end

$$D_{\frac{1}{3}h_{t2}} = D - 2\delta - \frac{2}{3}h_{t2} \times 2$$

Slot pitch at $\frac{1}{3}$ of tooth height from narrow end

$$\tau_{sg \frac{2}{3}h_{t2}} = \frac{\Pi D_{\frac{1}{3}h_{t2}}}{S_2}$$

Width of the tooth at $\frac{1}{3}$ of tooth height from narrow end

$$b_{t \frac{2}{3}h_{t2}} = \tau_{sg \frac{2}{3}h_{t2}} - b_{s2}$$

Area of one stator tooth at $\frac{1}{3}$ of tooth height from narrow end

$$= b_{t \frac{2}{3}h_{t2}} \times K_i l$$

Area of all the stator teeth under one pole

$$\begin{aligned} A_{t \frac{2}{3}h_{t2}} &= \text{Area of one tooth} \times \text{No of teeth per pole} \left(\frac{S_2}{P} \right) \\ &= b_{t \frac{2}{3}h_{t2}} \times K_i l \times \left(\frac{S_2}{P} \right) \\ &= \left[\frac{\Pi \left(D - 2\delta - \frac{2}{3}h_{t2} \times 2 \right)}{S_2} - b_{s2} \right] \times K_i l \times \left(\frac{S_2}{P} \right) \end{aligned}$$

So mean flux density in teeth

$$B_{t \frac{2}{3}h_{t2}} = \frac{\phi_1}{A_{t \frac{2}{3}h_{t2}}}$$

(6) Rotor copper loss

(a) Wound rotor:

Length of mean turns of rotor

$$L_{mt2} = 2L + 3.5\tau_p$$

DC resistance per phase at 75 °C

$$R_{Ph2,75^\circ C} = 0.021 \times 10^{-6} \times \frac{L_{mt2}}{F_{c2}} N_{Ph2}$$

We don't take the ac resistance because the rotor current frequency is very small ($f_2 = sf$)

$$\text{So Rotor cu loss} = 3I_{Ph2}^2 R_{Ph2}$$

(b) Cage rotor:

$$\text{Resistance of one bar} = 0.021 \times 10^{-6} \frac{L(m)}{F_{C2bar}(m^2)}$$

$$\text{Cu loss in bars} = S_2 \times I_{2bar}^2 \times \text{Resistance of one bar}$$

$$\begin{aligned} \text{Resistance of end ring} \\ = 0.021 \times 10^{-6} \frac{\Pi(D - 2\delta - 2d_{2bar})(m)}{F_{C2endring}(m^2)} \end{aligned}$$

$$\begin{aligned} \text{Cu loss in end rings} \\ = 2 \times I_{2endring}^2 \times \text{Resistance of one endring} \end{aligned}$$

$$\text{Total cu loss} = \text{Cu loss in bars} + \text{Cu loss in end rings}$$

Slip
$$S = \frac{\text{Rotor Cu Loss}}{\text{Rotor Input Power}}$$

$$S = \frac{\text{Rotor Cu Loss}}{\text{Mech Power Output} + \text{Losses}}$$

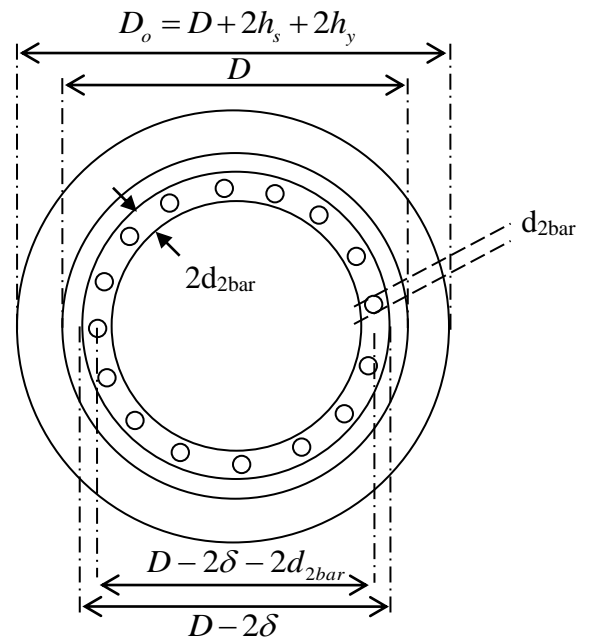

Losses = Rotor Iron Loss (Negligible) + Rotor Cu loss + F & W loss

F & W loss up to 5% for small motors
 3% to 4% for medium motors
 2% to 3% for large motors

S up to 5% for small motors
 2.5% to 3.5% for medium motors
 1% to 1.5% for large motors

EFFECTIVE AIR GAP LENGTH (δ'):

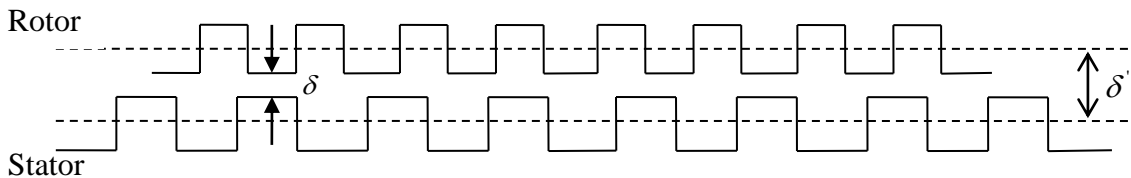

Effective air gap length

Where
$$\delta' = K_{C1} K_{C2} \delta$$

$$K_{C1} = \text{Gap Contraction factor for stator}$$

$$K_{C1} = \frac{\tau_{sg1}}{\tau_{sg1} - K_{01} b_{01}} \quad \& \quad \tau_{sg1} = \frac{\Pi D}{S_1}$$

$b_{01} = \text{stator slot Opening}$

$$K_{01} = \text{Carter's gap coefficient for stator} = \frac{1}{1 + 5 \frac{\delta}{b_{s1}}}$$

$K_{C2} = \text{Gap Contraction factor for rotor}$

$$K_{C2} = \frac{\tau_{sg2}}{\tau_{sg2} - K_{02} b_{02}} \quad \& \quad \tau_{sg2} = \frac{\Pi(D - 2\delta)}{S_2}$$

$$K_{02} = \text{Carter's gap coefficient for rotor} = \frac{1}{1 + 5 \frac{\delta}{b_{s2}}}$$

b_{02} = rotor slot Opening

FLUX DENSITY DISTRIBUTION:

Flux density at 30° from direct axis
= flux density at 60° from inter-polar axis

$$\begin{aligned} \text{So } B_{30^\circ} &= B_{60^\circ} = B_{m1} \cos 30^\circ \\ &= \frac{\pi - \sqrt{3}}{2} B \\ &= 1.36 B \end{aligned}$$

For all practical purposes this value is modified to

$$B_{30^\circ} = 1.35 B$$

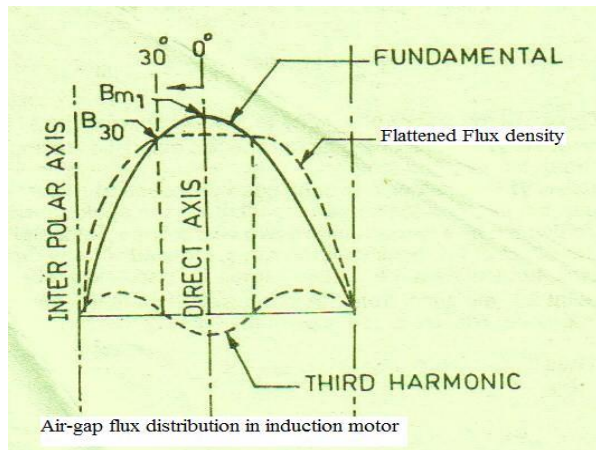

MMF REQUIRED IN AIR GAP ($AT_{\delta'}$):

$$H = \frac{1}{\mu_0} B \quad \text{AT/m}$$

$$AT_{\delta'} = \frac{1}{\mu_0} B_{30^\circ} \delta'$$

ESTIMATION OF MAGNETIZING CURRENT & NO LOAD CURRENT (I_m & I_0):

S.No	Part	Length of path	Flux density	at (AT/m)	$AT_{\text{pole-pair}}$
1	Stator Yoke	l_y	B_y	at_y	AT_y
2	Stator Tooth	$2h_{t1}$	$B \frac{1}{\frac{t_1}{3} h_{t1}}$	at_{2ht1}	AT_{2ht1}
3	Air Gap	$2\delta'$	B_{30°	$at_{2\delta'}$	$AT_{2\delta'}$
4	Rotor Tooth	$2h_{t2}$	$B \frac{1}{\frac{t_2}{3} h_{t2}}$	at_{2ht2}	AT_{2ht2}
5	Rotor Yoke	l_{ry}	B_{ry}	at_{ry}	AT_{ry}
$AT_{\text{pole-pair}} = AT_{30} = \sum$					

$$AT_{30} = AT_y + AT_{2ht1} + AT_{2\delta'} + AT_{2ht2} + AT_{ry}$$

$$\text{AT for one pole} = \frac{AT_{30}}{2}$$

So magnetizing component of no load current

$$I_m = AT_{30} \frac{P}{2} \frac{1}{1.17 K_{pd1} N_{Ph1}}$$

$$I_c = \frac{P_i}{3V_{Ph1}}$$

No load current

$$I_o = \sqrt{I_c^2 + I_m^2}$$

No load power factor

$$\cos \phi_o = \frac{I_c}{I_o}$$

ESTIMATIONS OF IDEAL BLOCKED ROTOR CURRENT:

Total resistance referred to stator

$$R_{01} = R_1 + R_2'$$

$$\text{Where } R_2' = \left(\frac{K_{pd1} N_{Ph1}}{K_{pd2} N_{Ph2}} \right)^2 R_2$$

Total leakage reactance referred to stator

$$X_{01} = X_1 + X_2'$$

$$\text{Where } X_2' = \left(\frac{K_{pd1} N_{Ph1}}{K_{pd2} N_{Ph2}} \right)^2 X_2$$

$$I_{sc, Ideal} = \frac{V_{Ph1}}{\sqrt{R_{01}^2 + X_{01}^2}}$$

$$\cos \phi_{sc} = \frac{R_{01}}{\sqrt{R_{01}^2 + X_{01}^2}}$$

ESTIMATION OF LEAKAGE REACTANCE:

Leakage reactance consists of

1. Stator slot leakage reactance
2. Rotor slot leakage reactance
 - (a) Wound rotor or
 - (b) Cage rotor
3. Overhang or end turns leakage reactance
4. Zigzag leakage reactance

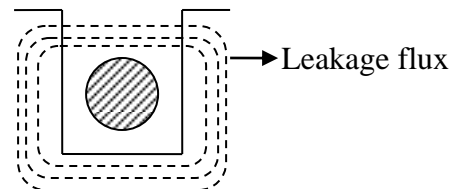

Slot leakage Reactance

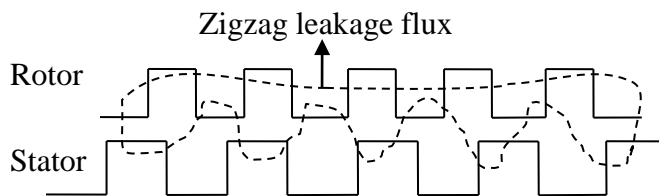

Zigzag leakage Reactance

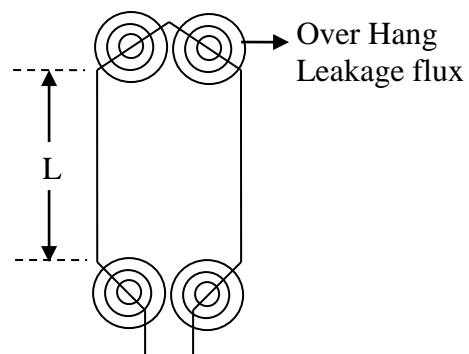

Over Hang Leakage Reactance

5. For cage rotor IM Zigzag leakage reactance is small and may be ignored.
- Differential or harmonic leakage reactance

1. Stator slot leakage reactance:

Assumptions are

- (i) Permeability of iron is infinity so NO MMF is consumed in iron path.
- (ii) Leakage flux path is parallel to slot width

Let

- I_{c1} = Conductor current (A)
- N_{c1} = No of conductors per slot
- Z_1 = Total No of conductors
- N_{Ph1} = Turns per Phase
- P = No of poles
- q_1 = Slot / Pole /Phase

(a) For 1-Layer winding

Total amp conductors in slot = $I_{c1} N_{c1}$

Consider an elementary path of thickness dx at a distance of x as shown in the figure. Let $d\phi_x$ be the leakage flux through the elementary path of thickness dx & height x .

MMF at distance x

$$M_x = \frac{N_{c1} I_{c1}}{h_1} x \quad \text{----- (1)}$$

$$\text{Permeance} = \mu_0 \frac{A}{L} = \mu_0 \frac{L dx}{b_{s1}} \quad \text{----- (2)}$$

So

$$d\phi_x = M_x \times \text{Permeance of the path}$$

$$d\phi_x = \frac{N_{c1} I_{c1}}{h_1} x \times \mu_0 \frac{L dx}{b_{s1}} \quad \text{---- (3)}$$

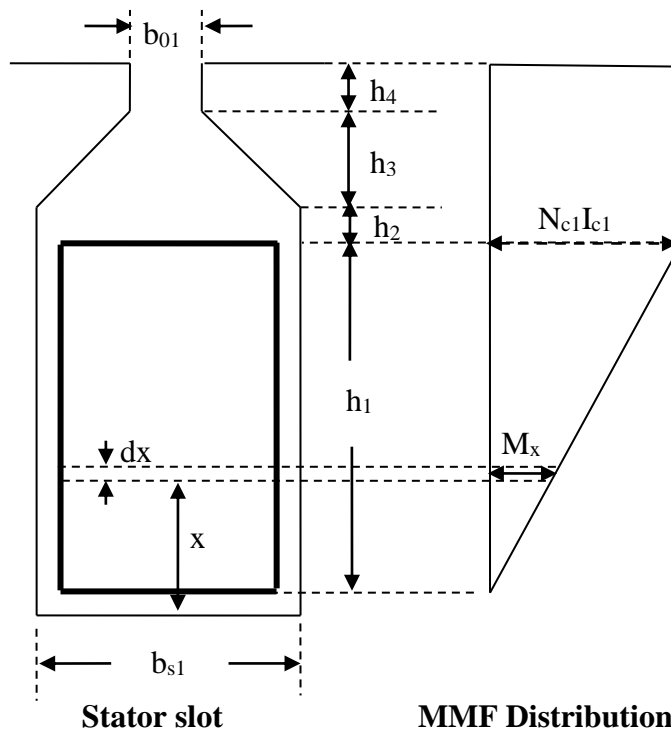

Leakage flux linkages associated with this elementary path

$$d\psi_x = \text{No of Conductors with which it is associated} \times d\phi_x$$

$$d\psi_x = \left(\frac{N_{c1}}{h_1} x \right) \times \frac{N_{c1} I_{c1}}{h_1} x \times \mu_0 \frac{L dx}{b_{s1}} \quad \text{----- (4)}$$

So flux linkages in height h_1

$$\psi_{h1} = \mu_0 N_{c1}^2 I_{c1} \frac{L}{b_{s1}} \int_0^{h_1} \left(\frac{x}{h_1} \right)^2 dx \quad \text{----- (5) (Integrating equation 4 from 0 to } h_1)$$

$$\psi_{h1} = \mu_0 N_{C1}^2 I_{c1} L \frac{h_1}{3b_{s1}} \quad \text{----- (6)}$$

Leakage flux linkages in height h₂

$$\psi_{h2} = \mu_0 N_{C1}^2 I_{c1} L \frac{h_2}{b_{s1}} \quad \text{----- (7)}$$

Leakage flux linkages in height h₃

$$\psi_{h3} = \mu_0 N_{C1}^2 I_{c1} L \frac{2h_3}{(b_{s1} + b_{o1})} \quad \text{----- (8)}$$

Leakage flux linkages in height h₄

$$\psi_{h4} = \mu_0 N_{C1}^2 I_{c1} L \frac{h_4}{b_{o1}} \quad \text{----- (9)}$$

Total slot leakage flux

$$\psi_{s1} = \mu_0 N_{C1}^2 I_{c1} L \left[\frac{h_1}{3b_{s1}} + \frac{h_2}{b_{s1}} + \frac{2h_3}{(b_{s1} + b_{o1})} + \frac{h_4}{b_{o1}} \right] \quad \text{----- (10)}$$

Slot leakage inductance will be

$$L_{s1} = \frac{\psi_{s1}}{I_{C1}} = N_{C1}^2 L \mu_0 \left[\frac{h_1}{3b_{s1}} + \frac{h_2}{b_{s1}} + \frac{2h_3}{(b_{s1} + b_{o1})} + \frac{h_4}{b_{o1}} \right] \quad \text{----- (11)}$$

$$L_{s1} = \frac{\psi_{s1}}{I_{C1}} = N_{C1}^2 L [\lambda_s] \quad \text{----- (12)}$$

Where

$$\lambda_s = \mu_0 \left[\frac{h_1}{3b_{s1}} + \frac{h_2}{b_{s1}} + \frac{2h_3}{(b_{s1} + b_{o1})} + \frac{h_4}{b_{o1}} \right] = \text{Specific slot permeance}$$

No of slots per phase = Pq₁

Slot leakage inductance per phase

$$L_{s1} / \text{Phase} = Pq_1 N_{C1}^2 L [\lambda_s] \quad \text{----- (13)}$$

Total No of conductors

$$Z_1 = N_{c1} \cdot 3q_1 \cdot P = 6N_{ph1}$$

So $N_{C1} = \frac{2N_{ph1}}{Pq_1}$ Put in above equation

$$\text{So } L_{s1} / \text{Phase} = Pq_1 \left(\frac{2N_{ph1}}{Pq_1} \right)^2 L [\lambda_s]$$

$$\text{Or } L_{s1} / \text{Phase} = 4\mu_0 \frac{N_{ph1}^2}{Pq_1} L \left[\frac{h_1}{3b_{s1}} + \frac{h_2}{b_{s1}} + \frac{2h_3}{(b_{s1} + b_{o1})} + \frac{h_4}{b_{o1}} \right] \quad \text{----- (14)}$$

Slot leakage reactance per phase (1-Layer)

$$X_{s1} = 2\pi f L_{s1} / \text{Phase}$$

$$X_1 = X_{s1} = 8\pi f \mu_0 \frac{N_{ph1}^2}{Pq_1} L \left[\frac{h_1}{3b_{s1}} + \frac{h_2}{b_{s1}} + \frac{2h_3}{(b_{s1} + b_{o1})} + \frac{h_4}{b_{o1}} \right] \quad \text{----- (15)}$$

(b) **For 2-Layer winding**

Same as 1-Layer winding

Slot leakage reactance per phase (2-layer)

$$X_1 = X_{s2} = 8\pi f \mu_0 \frac{N_{ph1}^2 L}{Pq_1} \left[\frac{2h_1}{3b_{s1}} + \frac{h_2}{4b_{s1}} + \frac{h_3}{b_{s1}} + \frac{2h_4}{(b_{s1} + b_{01})} + \frac{h_5}{b_{01}} \right] \text{----- (16)}$$

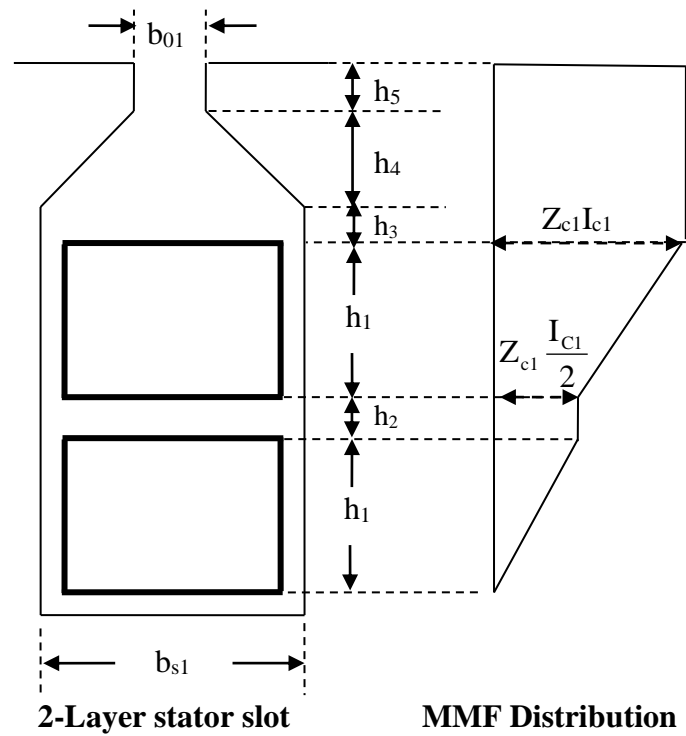

2. Rotor slot leakage reactance(X_2)

(a) **Wound rotor:** Estimated in the same manor as for stator.

(b) **Cage rotor:**

$$W_0 = b_{02} = (0.2 \text{ to } 0.4) d_{2bar}$$

$$h = 1 \text{ to } 3 \text{ mm}$$

Rotor reactance per phase

$$X_2 = 8\pi f \frac{N_{ph2}^2 L}{Pq_2} [\lambda_r] \text{----- (17)}$$

Where

$$\lambda_r = \text{Rotor Specific Permeance}$$

$$\lambda_r = \mu_0 \left(0.623 + \frac{h}{W_0} \right)$$

Rotor resistance referred to stator

$$X_2' = \left(\frac{K_{pd1} N_{ph1}}{K_{pd2} N_{ph2}} \right)^2 X_2$$

Where

$$N_{ph2} = \frac{S_2}{2 \times 3}$$

3. Overhang leakage reactance(X_0):

$$X_0 = 8\pi f \frac{N_{ph1}^2 l_0}{Pq_1} [\lambda_0] \text{----- (18)}$$

Where

$$\lambda_0 = \text{Overhang Specific Permeance}$$

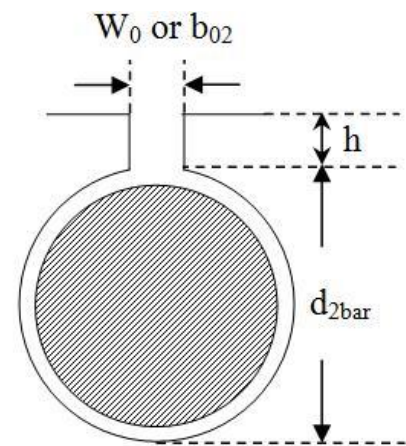

Cage Rotor with Round Slot

$$\lambda_0 = \mu_0 K_s \frac{\tau_p^2}{l_0 \pi \tau_{sg}}$$

l_0 = Length of conductor in overhang

K_s = Slot leakage factor

τ_p = Pole Pitch

τ_{sg} = Slot Pitch

4. Zigzag leakage reactance (X_z):

$$X_z = \frac{5}{6} X_m \left(\frac{1}{S_{p1}^2} + \frac{1}{S_{p2}^2} \right) \quad \text{----- (19)}$$

Where

$$X_m = \frac{V_{ph1}}{I_m} \quad S_{p1} = \frac{S_1}{P} \quad \& \quad S_{p2} = \frac{S_2}{P}$$

5. Differential or Belt or Harmonic leakage reactance (X_h):

It is ignored for cage rotor but considered for wound rotor IM. It is due to the fact that spatial distribution of MMFs of the primary and secondary windings is not the same; the difference in the harmonic contents of the two MMFs causes harmonic leakage fluxes.

$$X_h = X_m (K_{h1} + K_{h2}) \quad \text{----- (20)}$$

Where

K_{h1} & K_{h2} are the factors for stator & rotor

Hence

Total leakage reactance referred to the stator side

$$X_{01} = X_1 = X_{s1} + X_2' + X_0 + X_z + X_h$$

CONSTRUCTION OF CIRCLE DIAGRAM FROM DESIGNED DATA:

We should know following for drawing the circle diagram

- No load current and no load power factor
- Short circuit current and short circuit power factor

Steps to draw the circle diagram are (See the figure)

- Draw horizontal (x-axis) and vertical (y-axis) lines.
- Draw I_0 at an angle ϕ_0 from vertical line assuming some scale for current.
- Draw I_{sc} at an angle ϕ_{sc} from vertical line.
- Join AB, which represents the o/p line of the motor to power scale.
- Draw a horizontal line AC, and erect a perpendicular bisector on the o/p line AB so as to meet the line AF at the point O'. Then O' as center and AO' as radius, draw a semi circle ABC.
- Draw vertical line BD; divide line BD in the ratio of rotor copper loss to stator copper loss at the point E.
- Join AE, which represent the torque line.

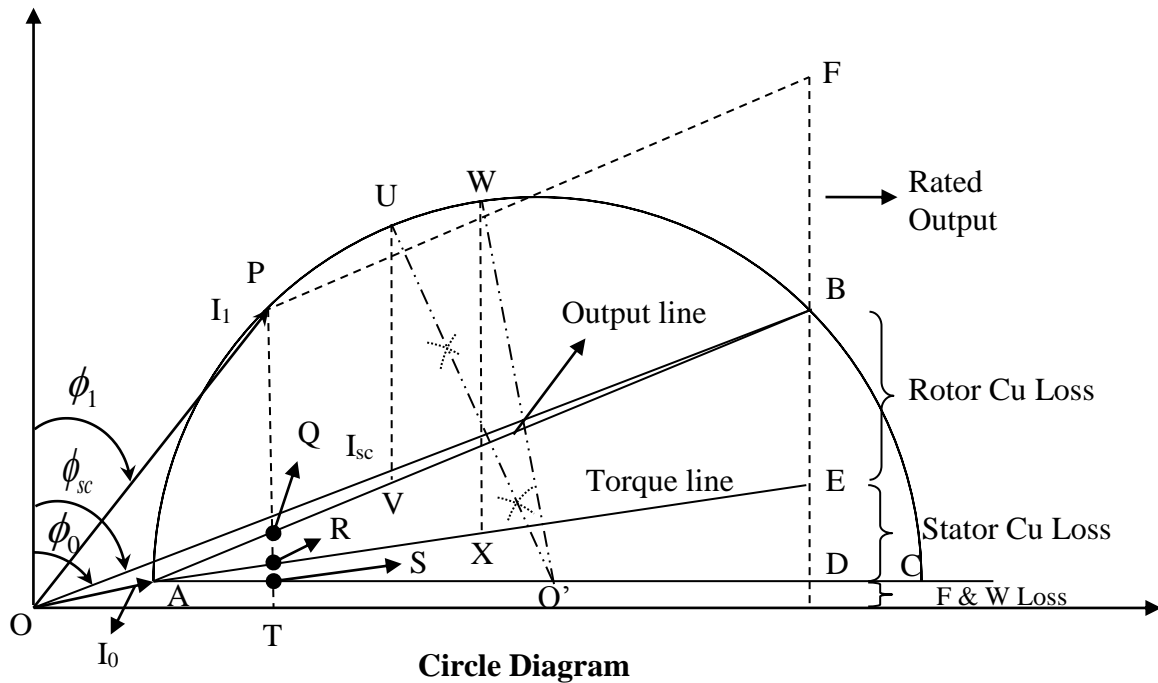

Determination of design performance from above circle diagram

1. Power scale can be find out from current scale
 Power in watt per Cm = Voltage x Current per Cm

2. Full load current & power factor
 Draw a vertical line BF representing the rated o/p of the motor as per the power scale. From point F, draw a line parallel to o/p line, so as to cut the circle at pint P. Join OP which represents the full load current of the motor to current scale.
 Operating power factor = $\cos \phi_1$

3. Full load efficiency
 Draw a vertical line from P as shown in above figure.
 PQ = O/p Power
 PT = I/p Power

$$\eta = \frac{PQ}{PT}$$

4. Full load slip

$$Slip = \frac{Rotor\ Cu\ loss}{Rotor\ Input\ Power}$$

$$= \frac{QR}{PS}$$

5. Torque: Line PS represents the torque of the motor in synchronous watts on power scale.

6. Maximum power output: Draw perpendicular line from O' to line AB (o/p Line), which intersect circle at point U. Now draw vertical line UV.
 Maximum power output = UV

7. Maximum Torque: Draw perpendicular line from O' to line AE (torque Line), which intersect circle at point W. Now draw vertical line WX.
 Maximum Torque = WX (Synchronous Watt)

